



## Terminal Boxes

BARTEC TECHNOR offers a wide range of standard junction box sizes in stainless steel 316L, GRP and aluminium. Enclosures may be manufactured in customized sizes with various extra facilities/ accessories for multiple purposes. Standard enclosures can be delivered with optional solutions:

- Lids with hinges/bolts, hinges/quicklocks or bolts only.
- Glandplates according to customers specifications.
- Multi Cable Transit (MCT).
- Multidoor cabinets.
- High voltage solutions (Bus bars).



TNCN terminal box, Ex e/i, stainless steel 316L for use in any environment where an explosive atmosphere may be present. The enclosures are especially recommended for chemical agent environments, seawater corrosion resistance and extremes of low and high temperatures.

## Flameproof Enclosures

BARTEC TECHNOR's range of Ex d enclosures is stainless steel, painted steel and copper free aluminium, in several standard sizes. The enclosures are available with or without Ex e connection box and inspection window. The range consists of:

- Ex d IIC, SS316 / CF-3M.
- Ex d IIC, cylindrical, SS316 / CF-3M.
- Ex d IIC, painted copper free aluminium.
- Ex d IIB, SS316 / CF-3M.
- Ex d IIB (+H<sub>2</sub>), painted copper free aluminium.



TNCD enclosures, Ex d/de made of stainless steel are designed to meet the requirements for Ex d IIC equipment in harsh environments on- and offshore. TNCD can be delivered as Ex d direct entry or as an Ex de combination for indirect entry.





### Pressurized Systems and Cabinets

BARTEC TECHNOR's pressurized systems are built using stainless steel cabinets, designed according to customer specifications. We have many years experience with supply of complete and certified "plug-and-play" Ex p systems.

- Large cabinets up to 2000 litres.
- Several cabinets can be connected together.
- Tailor made sizes and designs.
- Fully electronic purge control system.
- Optional large purge flow when short purging time is required, as well as large maintenance flow to flush dissipated heat out of the cabinet.
- Windows in different sizes and materials can be provided in the cabinets.



The TNCNP range of Ex p pressurized systems are designed and purpose built according to each client's requirements. The equipment allows for use of standard (non-Ex) electrical components in Ex Zone 1 and 2.

BARTEC TECHNOR delivers turn-key solutions with enclosures made in stainless steel 316L, complete with purge control apparatus, testing and certification.

Certified according to ATEX, IECEx, CSA, INMETRO, KOSHA, NEPSI and GOST



TNXCD cylindrical enclosures, Ex d/de in stainless steel SS316 / CF-3M are designed as slim, compact, multipurpose enclosures. A typical application for this enclosure is CCTV camera housing.



The TNBCD range of enclosures is manufactured in stainless steel SS316 / CF-3M, and is designed to meet the requirements for Ex d IIB equipment in harsh environments on- and offshore. It can be configured as Ex d direct entry or as an Ex de indirect entry.



The DE8BC range of Ex d IIB enclosures is manufactured in stainless steel 316L. The enclosure can be configured as Ex d direct entry or as an Ex de combination for indirect entry. If required, several enclosures can be assembled on a frame with separate or common Ex e/i junction boxes.

### Ex Compact Air-Conditioning Unit

The EC type examination certified Ex Compact Air-Conditioning Unit (FKS-CLM) is suitable for a fixed installation on a vertical mounting surface. Its main purpose is the removal of heat dissipated from electrical and mechanical production equipment and of the weather dependent thermal irradiation on analysis equipment rooms of zones 1 and 2.

With economical use the cooling system effects a higher functionality and availability as well as an increased added value with all process analyzers and subsystems for control of product quality that are housed in the instrumentation and control rooms for the chemical or petroleum industries.





## Audible and Visual Signals

Beacons with many options and combinations of operating voltages, triggering facilities, dome colours and oscillator cards for audible warning.

- Ex d or Ex de in stainless steel 316L / CF-3M.
- Medium intensity Obstruction Light, with low heat dissipation, low power consumption and maintenance free.



The TNFCD range of flashing beacons is designed to withstand harsh off-shore environments. They are suitable for areas where an explosive atmosphere may be present and the need for warning is required. TNFCD flashing beacons are available as Ex de indirect entry, Ex d direct entry or as Non-Ex. Special applications can be designed upon request.

## Lighting

For special lighting applications BARTEC TECHNOR can provide helideck floodlights and LED based backlights for level gauges.

Housings are available stainless steel 316L / CF-3M.



The TNXCX Ex d IIC low profile Xenon helideck floodlights are manufactured in stainless steel 316L / CF-3M, and are developed to withstand harsh offshore environments while providing safe, powerful illumination with no glare (e.g. to pilots or crew). High quality electronics provide a reliable and long-life source to minimize maintenance.



The TNCLS range of Ex em LED backlights are designed for use to illuminate level gauges in all kinds of industry where an explosive atmosphere may be present. TNCLS offers a long life and low maintenance LED solution.





## Plugs & Sockets - AMPHENOL

The Amphenol STARLINE EX-series is the reference in flameproof connectors for the Oil & Gas and Marine industry for signal, power and RF requirements in the most harsh environments. Made of high tensile strength aluminum with hard anodic coating. Also available in high grade 316 stainless steel.



### Key Features

- ATEX/IECEX certified for Zone 1 IIC.
- Inserts from single-contact up to 143 contacts and 1135 Amps./1000VAC or DC
- IP 68.
- Temp. – 40 to + 55°C.
- Shock resistance 60G.
- Double lead threaded coupling system.
- Wide variety of mech. clamps and kellems grips.

### Typical applications:

- Petro-chemical plants.
- Offshore oil drilling.
- Automotive paint booths.
- Aircraft refuelling pits.
- Pharmaceutical manufacturing equipment.

## Gas Detection

The EXguard™ System is built for local monitoring of areas where hot work takes place and gas may be present. A separate work station with outlets for high currents can be supplied as an option. Trolley, enclosures and sensor drums are made of stainless steel 316L / CF-3M.

The EXguard™ System is certified according to ATEX / IECEx



The EXguard™ System is specially designed for use in Zone 1 and 2 where hot work takes place in open areas as well as in habitats.

Upon detection of gas, connected electrical and pneumatic tools are automatically shut down and audible and visual warning will be given.





## Operating units / HMI

- PC with or without touch screen.
- Terminals.
- Screen sizes - 5.7", 10.4", 12.1", 15", 19", 22"W, 24"W.
- 15" sunlight version.
- Wireless or wired communication.
- Keyboard, joystick, tracker ball, mouse etc.
- Stainless steel enclosures.

The panel PCs and remote units in the POLARIS series are the perfect solutions for control and operation of complex systems in potentially hazardous areas.



## Mobile Computing

- WLAN (Wifi) / WWAN (3G) / GSM.
- Barcode scanning.
- RFID.
- Bluetooth.

In cooperation with Motorola, BARTEC is offering an explosion-proof versions of Motorola Mobile Computer range. The Mobile Computers offers reliable performance and large capacity - even in complex applications. The product are very user-friendly due to use of Windows Mobile Operating System and the real-time communication via common wireless protocols.



## Bus and Interface technology

- Bus systems for PROFIBUS-DP.
- Control Units MODEX.

MODEX bus modules are used to conduct standard bus systems continuously from the safe area into the hazardous area, simply and without much expense. The direct networking significantly reduces the costs of planning, installation and testing. MODEX is the perfect stop for all buses. MODEX control units include power supplies, transformers, power converters, isolators, optocouplers, fuses, resistors and a variety of relays.

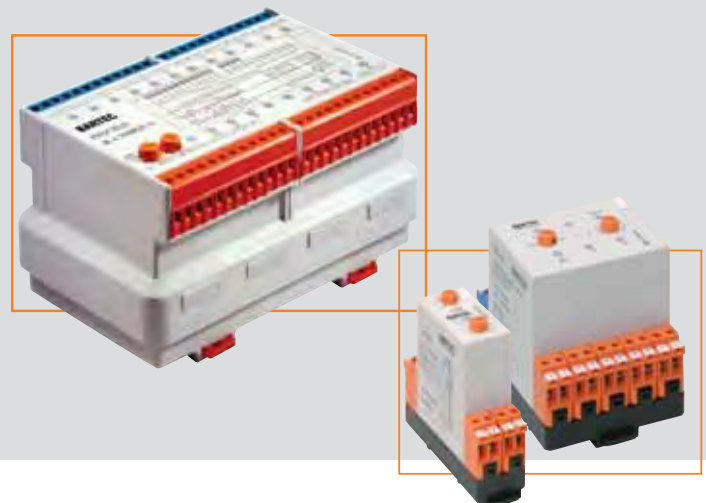



## I/O Systems

- Remote I/O solutions

ANTARES is a modular remote I/O system for both PROFIBUS-DP, ProfiNet, Ethernet IP and Modbus TCP, and is BARTEC's response to industry's requirements for more economic efficiency, convenience and flexibility.

The RCU is the central head unit in the ANTARES system and accommodates data processing, power management and an Ethernet switch. Innovative interlocking technology ensures a stable and safe connection. The high-output power supply allows supply of up to 32 modules per RCU, and a large number of sensors and actuators can thus be connected.

The range of different modules offers a lot of possibilities. Just join them together and the connection is secure, even over several mounting rails. Standard mounting rails will suffice; complex bus rails are no longer necessary. With PROFIBUS-DP, the highest system stability is achieved through a redundant structure with 2 top modules. In addition, all modules are hot-swappable, i.e., it is possible to change modules during ongoing operation of the energized system. The PROFIBUS or Ethernet line can be connected directly to the system without use of additional explosion-protected components like isolating repeaters.

ANTARES can be installed directly in the hazardous area in ATEX zones 1 and 2 (gas) - and is also certified for ATEX zones 21 and 22 (dust). The system does not require an Ex e enclosure for equipment category 2G, only mechanical protection. The ANTARES designer software allows the system to be easily projected and configured with just a few mouse clicks due to its intuitive operability.



## Network Technology - ATEX Ethernet switches and media converters for Zone 1

The BNT range of ATEX certified Ethernet switches, fiber transceivers and media converters are designed to provide safe connections and communication in Ex areas. The switches and media converters can be installed directly into the potentially explosive atmospheres, including Zone 1/21, and can be used to transfer optical or electronic data signals for bandwidth up to of 1 Gbps. The products are available in an aluminum housing as well as in a stainless steel housing that also enable use in the mining area M2.



The optical transceivers in the BNT series are characterized by their intrinsically safe fiber optic cable connections (opis) that guarantees safe communication into potentially explosive atmospheres.

The common connector types SC, ST and LC are available - as well as the possibility of a redundant power supply.



## PAGA and Driller's Intercom

Our range of communication systems for use in the offshore and onshore petrochemical industry includes:

- P3 Public Address and General Alarm [PAGA] Systems.
- P3 Page-Party-PABX Two Way Communications Systems.
- DX3+ Driller's Intercom Systems.
- Certified field equipment including explosion proof loud speakers, flashing beacons, junction boxes, and high performance acoustic hoods & booths.

We provide client specific packages which include project management, acoustic responsibility, commissioning and site support.







## Heating Cables

Heating tape for frost protection, maintaining temperature and heat-up in pipes, tanks, vessels or at surfaces in non-ex areas and in explosive atmospheres. BARTEC heating tape is available with different power 10W/m up to 98W/m outputs and outer protective covers.

- Self-limiting parallel heating cables PSBL, PSB, HSB and HTSB.
- Single-core PFA-insulated heating cables EKL light, EKL medium, EKL Premium.
- Mineral-insulated heating cables EMK.
- Easy on-site cutting and terminating, even in Ex areas.
- Corrosion-proof and resistant to effects of chemicals, thanks to its protective outer sheath.

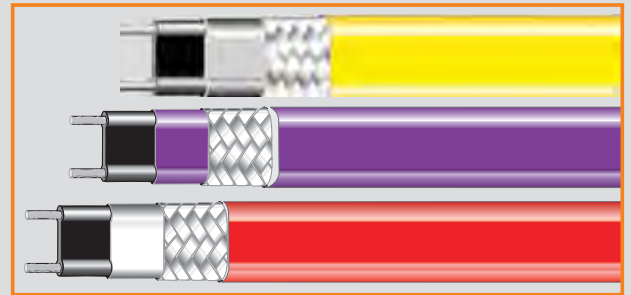

## Connecting systems

To suit the varying heating cables and areas of applications, you have a choice between different connecting systems:

- Simply ingenious and flexible: PLEXO, TWISTO, CONPAC.
- Exceptionally economical: silicone cold-applied connection technology and heat-shrink technology.
- Large range of junction boxes made of plastic, aluminium or stainless steel.



## Control units and Temperature sensors

- Electromechanical and electronic regulating and control units for use in Ex areas and for industrial applications.
- Ambient thermostats, two-position controllers, proportional devices, PID control units.
- Single-channel and multi-channel control systems.
- Pt100 temperature sensors for use in Ex areas and for industrial applications.







## Heaters

- Heater elements for use in Ex areas, 50W up to 600W.
- Mini heaters, 6W.
- Anti-condensation heater for motors.



## Skin Effect Heating System

The SEH is an industrial electric heating system using the AC phenomenon with a remarkably effect on the inner surface of a ferromagnetic tube. Different from other technologies, it offers great advantages for long lines applications up to 20 km with only one feeding point. The capabilities goes up to +200 °C applications in explosion-hazardous or non-hazardous areas.



## Project engineering software

We have developed the efficient and easy-to-operate project engineering software HELOC specially for users. It is ideal for designing heating circuits, calculating heat loss, selecting heating cables and accessories.

Free download from BARTEC TECHNOR's website.





## ComEx Control stations

ComEx is a highly flexible system with a variety of standard enclosures and various actuating elements, switch- and lamp modules.

The ComEx enclosures are available in highly impact-proof plastic. The enclosure series and every individual display and switching element are certified for use in Zone 1 and Zone 2 hazardous areas.

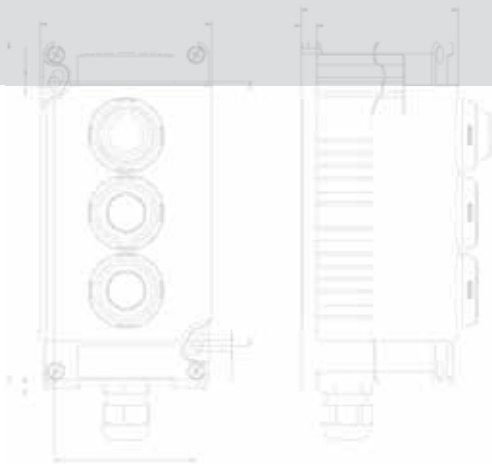

## Work light

This mobile LED work light with rechargeable battery technology serves to illuminate workplaces in hazardous environments.

The work lights can be used in hazardous areas in Zone 0, 1 and 2 in compliance with the gas-sub-groups IIA, IIB and IIC, and the temperature class T4 as well as in Zone 20, 21 and 2 in conformance to the certified maximum surface temperature.

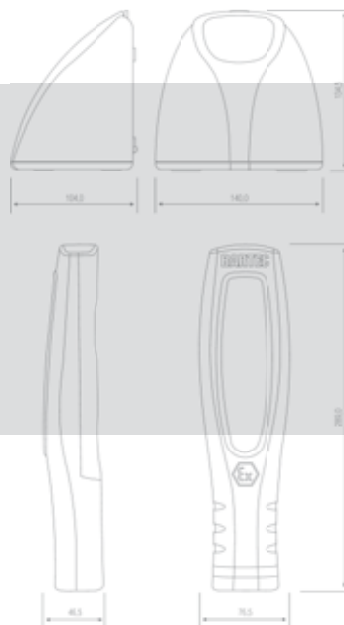



## Motors

Explosion-protected electric motors are used in industrial plants with a potentially explosive atmosphere containing inflammable fumes (vapours) or gases (at chemical industry, oil refineries) as well as in mines where methane is present.

The range are the three-phase, asynchronous electric motors with short-circuit rotor, explosion protected according to the CENELEC EN 60079-0, EN 60079-1, EN 60079-7 standards.

Electric motors are of totally enclosed, fancooled (blow-over) type. Cooling is provided by fans blowing external air over the ribbed outside surface (cooling system IC 411 according to IEC 34-6 or EN60034-6). Electric motors up to 225 frame size are made of cast iron. Motors frame sizes of 250 and more are made of welded housing and the terminal boxes of cast iron.

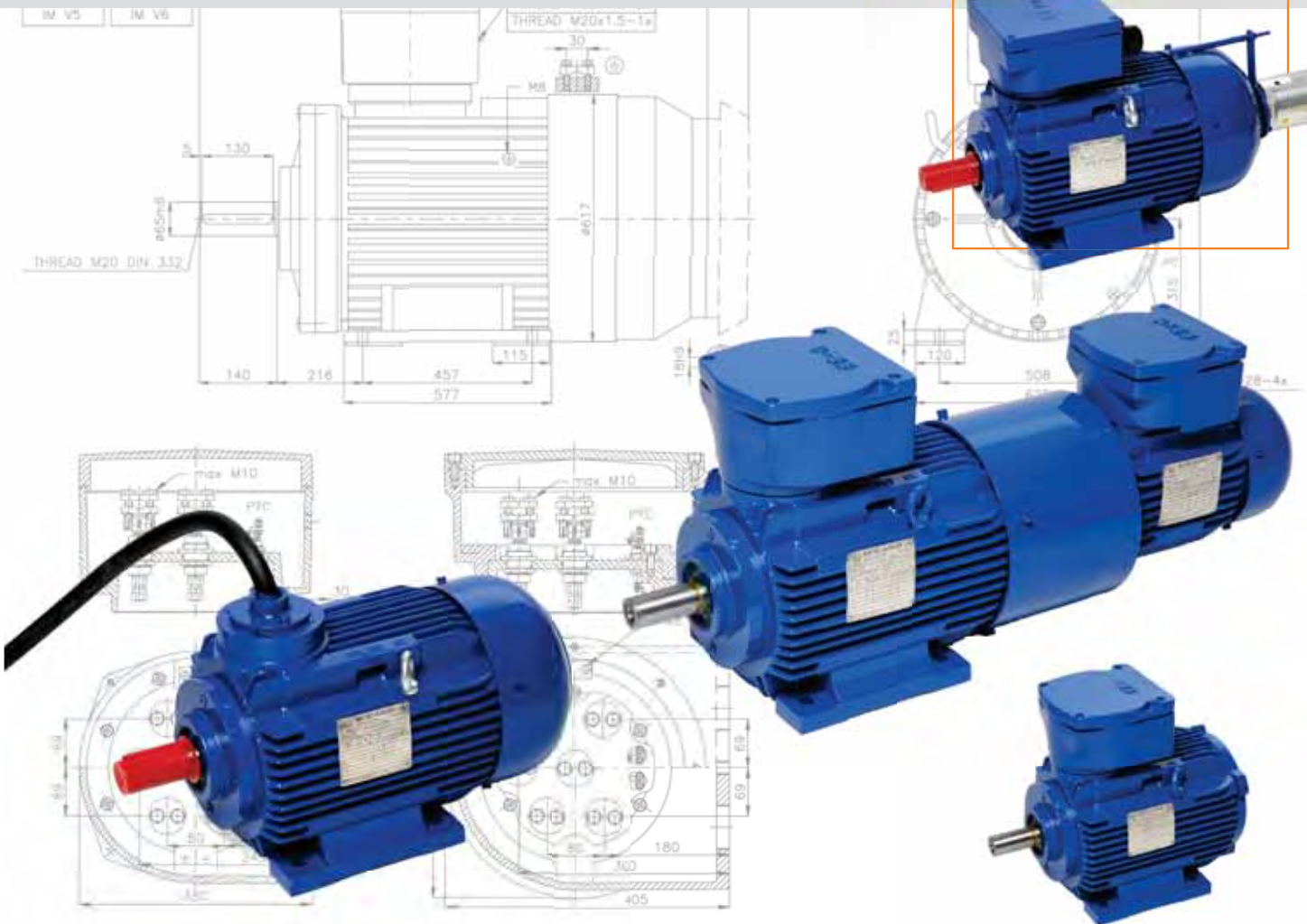



**RADOX MFH SB offshore cable**

DNV approved and resistant to oil and drilling fluids according to NEK TS 606:2009. Replaces the traditional RFOU but have only 1/3 of the weight and thickness. Extremely flexible and can be installed in flexible installations like drag chains/cable carriers etc. One range only that cover both signal and power (0,6/1kV). All cables are with screen/armour that can be used as earth in accordance to NEK606 and IEC 61892-4. Excellent mechanical properties - DNV tested and approved according to TAP 6-827.11 incl. cold impact/bend, scratch and tensile tests. Sheath: RADOX Elastomer SFH (SHF2, SHF mud). Color: black. IEC 60228 Class 5 flexible conductor's absorbs vibration better (RFOU class 2). Multicore/twisted pairs/ twisted pairs with individual screen 0,5-6mm<sup>2</sup>.



<b>Applicable EX protection</b>	
<p><b>Ex e Protection</b> for electrical components that do not spark under normal working conditions but where measures are applied to prevent high temperatures and the occurrence of arcs and sparks internally.</p>	
<p><b>Ex i Protection</b> for equipment containing intrinsically safe circuits, which are incapable of causing an explosion in the surrounding atmosphere, that is where current and voltage in normal operation would not produce enough spark energy or heat to ignite any potentially explosive gases.</p>	
<p><b>Ex d Protection</b> Parts, which can ignite a potentially explosive atmosphere, are surrounded by an enclosure, which are designed to withstand the pressure of an internal explosion and to prevent the propagation of the explosion to the atmosphere surrounding the enclosure.</p>	
<p><b>Ex m Protection</b> Parts that could ignite a potentially explosive atmosphere by means of heat or sparks are embedded in a sealing compound such that the potentially explosive atmosphere cannot be ignited. The compound is resistant to physical, electrical, thermal and chemical influences.</p>	
<p><b>Ex p Protection</b> The ingress of the surrounding atmosphere into the housing of electrical equipment is prevented by maintaining an ignition shield gas (air or a different suitable gas) inside the housing at a pressure above atmospheric pressure. Overpressure is maintained with continuous flushing of the protective gas.</p>	

**Zone Classification with the presence of GAS**

Zone 1 (Category 2)	An area in which explosive gas is likely to be present during normal operation of the plant.
Zone 2 (Category 3)	An area in which explosive gas is not continuously present, but may exist for a short period of time.

**Zone Classification with the presence of DUST**

Zone 21	An area in which an explosive atmosphere in the form of a cloud of combustible dust in air is likely to occur in normal operation of the plant.
Zone 22	A place in which an explosive atmosphere in the form of a cloud of combustible dust in air is not likely to occur in normal operation, if it does occur, will persist for a short period only.

